

How
to build
your
dome.

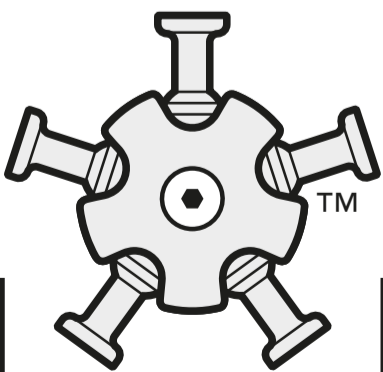

hubsTM

Version I
Waterproof and tearproof

Parts checklist

I. To build the dome

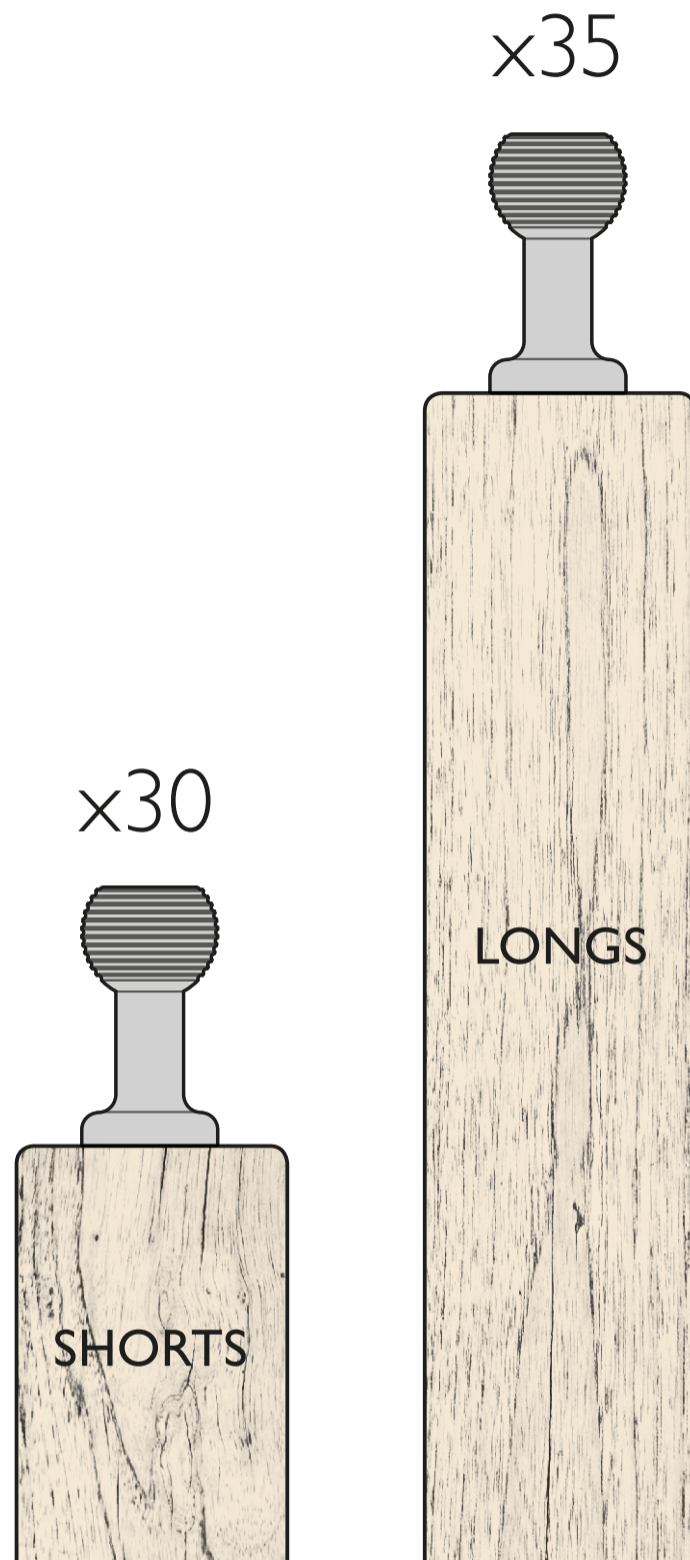
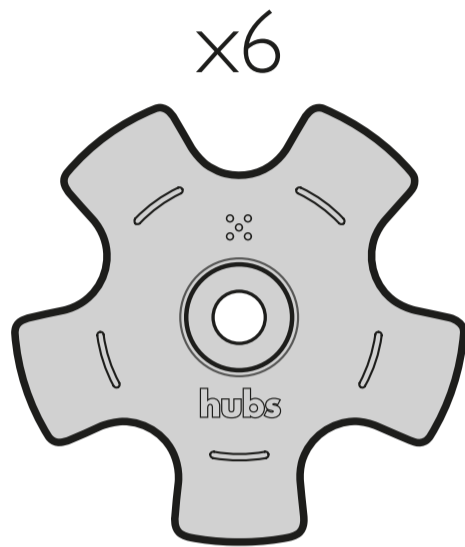

For the base

You will need another 10 wood screws or another 20 ball connectors and 20 wood screws depending on which base approach you go for. These are included in the kit. See the *Completing your dome* section for more.

2. To clamp-up the hubs

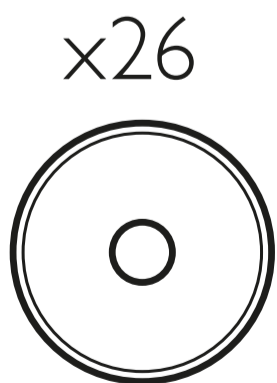

Locking plate
Clamps the ball connectors in place once the dome is in its final position.

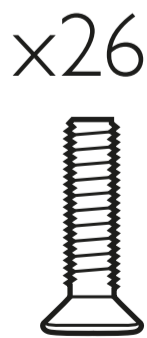

Hub screw
Goes through the centre of the hub for clamping.



Wing nut
Screws onto the end of the hub screw to clamp the locking plate in place.

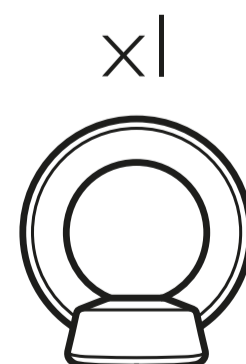

Hanging eyelet
Use this to hang something nice from the centre of your dome.

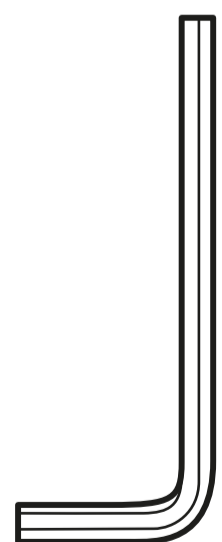

Allen key
Used to hold the hub screws in position when clamping the hubs.

Principles

These are useful things to remember to help the build go smoothly.

1

It takes two

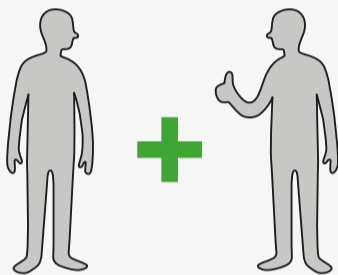

One can connect as the other lifts.

2

Stay on the outside during the build

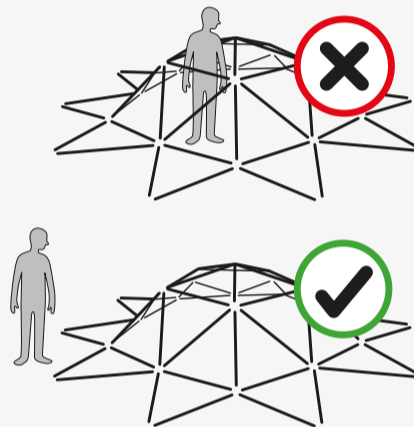

3

Insert from below

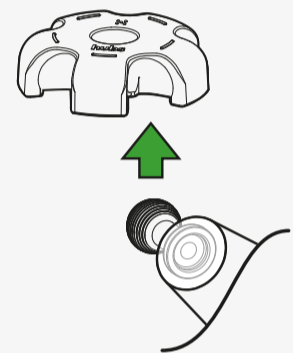

Insert and remove ball connectors in this alignment.

4

Lift the hub above to enable connection

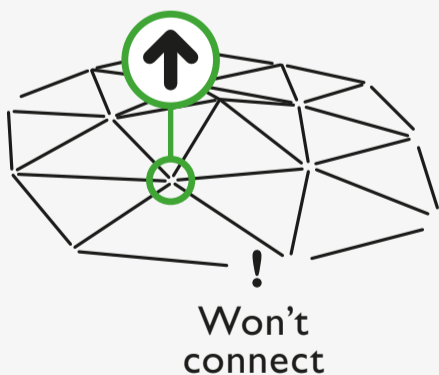

5

Lift by the sticks above the hub

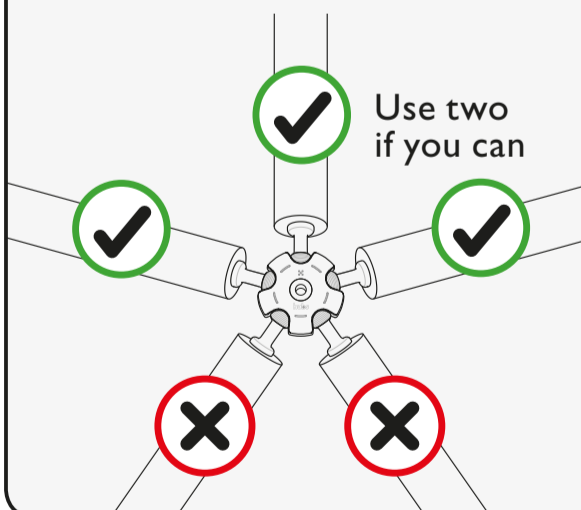

6

Only clamp-up hubs when the dome is in its final position



Moving the dome whilst clamped-up will damage the hubs and ball connectors!

Watchouts!

Building your dome should be great fun and the last thing we want is for people to hurt themselves. Here are a few things to watch out for:

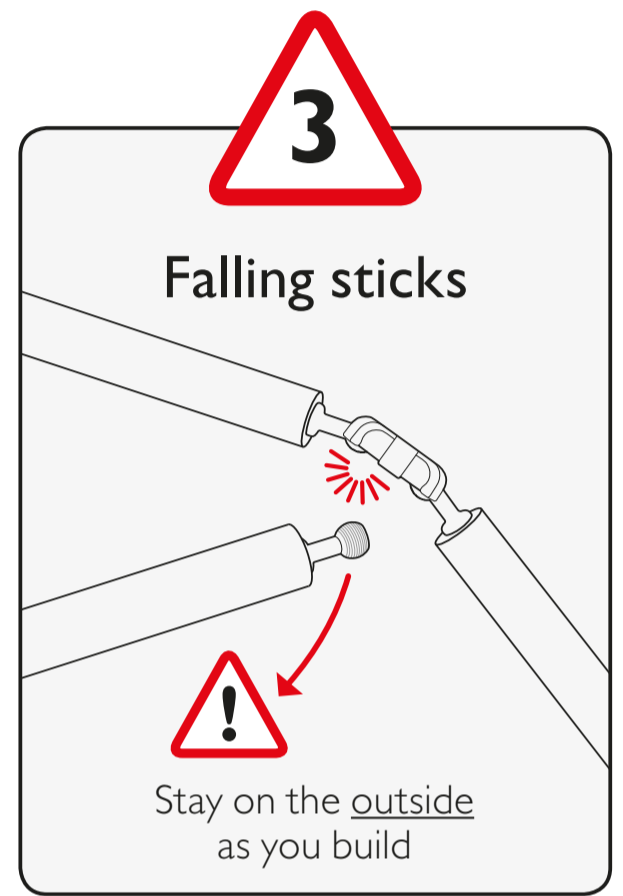
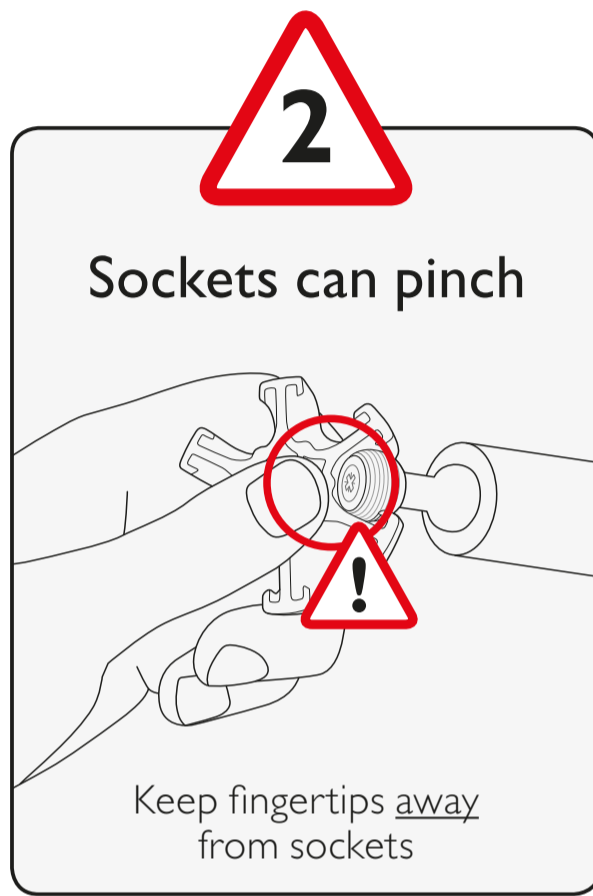
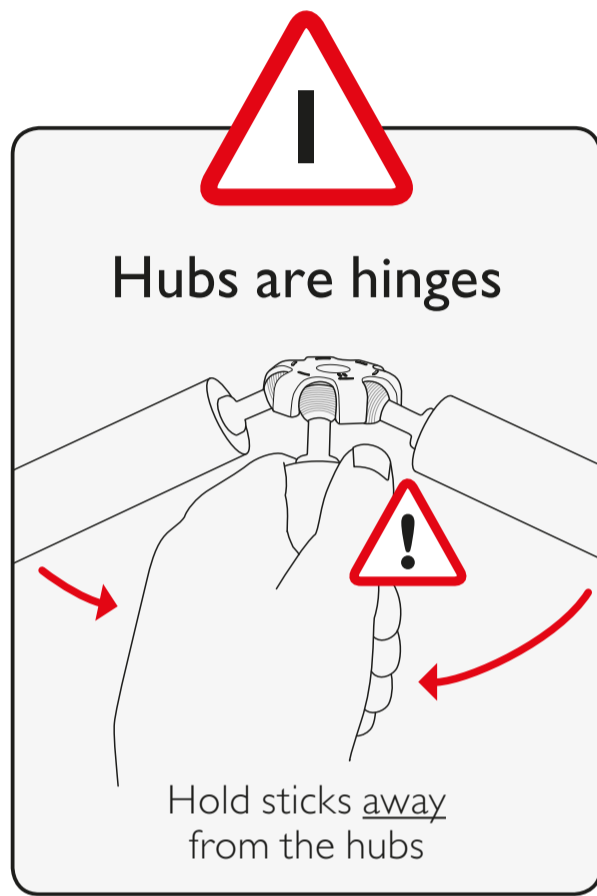

Tip:
Wearing gloves
minimises the risk.

Tip:
If a stick pops-out
just pop it back in!

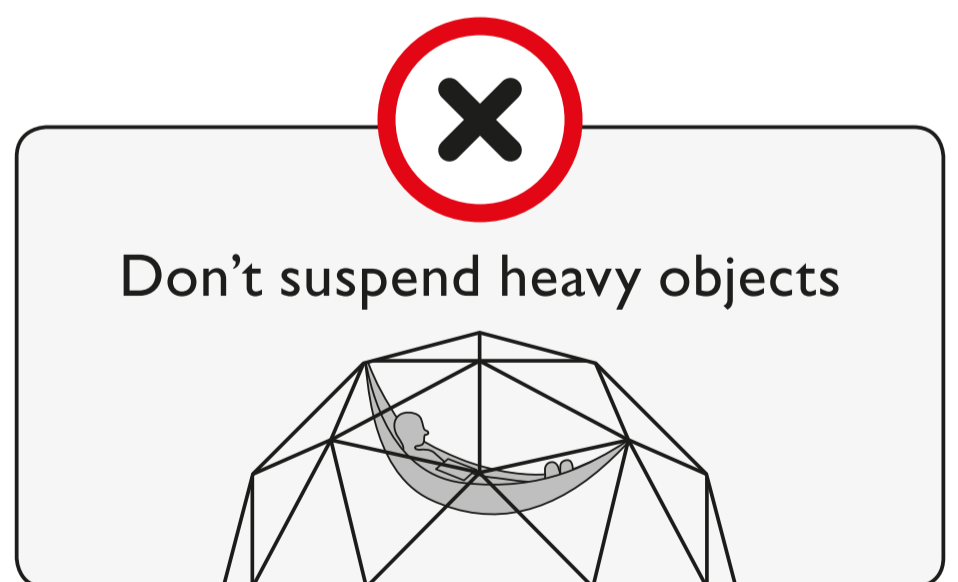
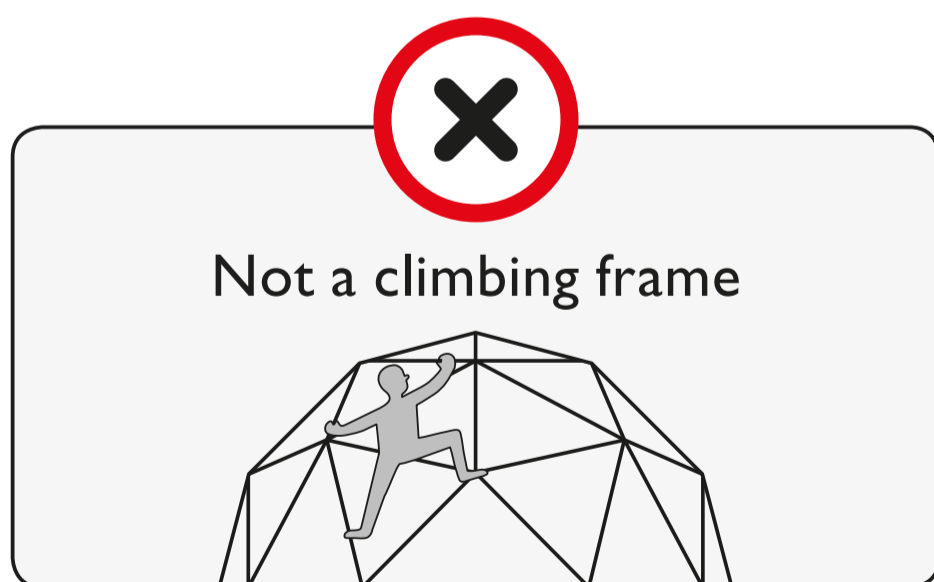

The benefits that hubs bring to the build and adaptation of domes comes at the cost of ultimate strength.

Domes built with hubs are still satisfyingly sturdy structures which are more than strong enough for their intended uses; eg fruit cages, garden rooms, chicken runs etc.

The build

Read out the descriptions and check progress against the illustrations.

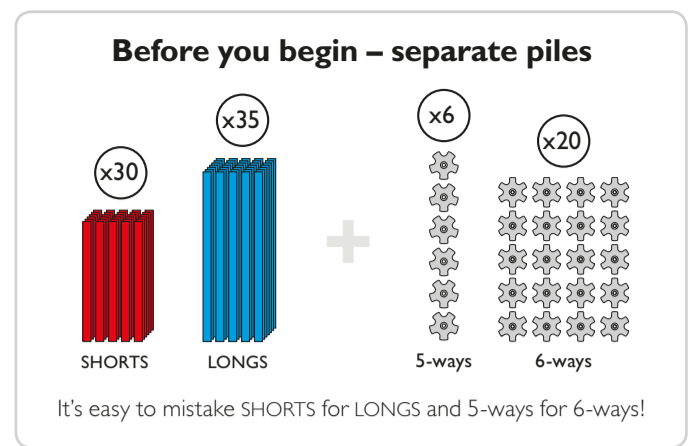

Step	You need	Description (read this out to someone helping you)	It should look like this!
1		<ul style="list-style-type: none"> Start with a <u>5-way</u> hub in the middle and connect <u>five</u> SHORTS into it. – hubs should always face up and sticks always connect in from below. 	
2		<ul style="list-style-type: none"> Snap a <u>6-way</u> hub onto the end of each SHORT. Place <u>five</u> LONGS around the outside and connect them into the 6-way hubs. <u>Lift</u> the centre 5-way hub by its sticks to make the final connection. 	
3		<ul style="list-style-type: none"> Connect a <u>pair</u> of LONGS into the left and right free sockets of the 6-way hubs (keep the middle socket free). Use 6-way hubs to connect the LONGS together to create triangles. 	
4		<ul style="list-style-type: none"> Connect a <u>SHORT</u> into the remaining free socket of each 6-way hub. Snap a <u>5-way</u> hub onto the end of each SHORT. 	
5		<ul style="list-style-type: none"> Place <u>ten</u> SHORTS in a ring around the structure so far. Work your way around the ring, connecting the sticks one at a time – when you can't make a connection <u>lift</u> the hub above. 	
6		<ul style="list-style-type: none"> Connect <u>two</u> SHORTS into the 5-way hubs and <u>two</u> LONGS into the 6-way hubs. 	
7		<ul style="list-style-type: none"> Use <u>ten</u> 6-way hubs to connect SHORTS and LONGS together into triangles. – use sockets that are next to each other on the hubs. 	
8		<ul style="list-style-type: none"> Place <u>ten</u> LONGS in a ring around the outside. Work your way around the ring, connecting the sticks one at a time – use sockets either side of those already populated. – when you can't make a connection <u>lift</u> the hub above. 	

DOME DONE!

Check out the *Completing your dome* section for next steps.

Completing your dome

Once you've built your dome, move it into its final position before clamping-up the hubs. Two people should be able to drag your dome to another position. We'd recommend four people or more if you are lifting the dome.



Anchor your dome
Whichever base approach you use ensure that the dome and any cover is securely anchored to the ground. Wind can place an enormous force on sheet covers and even netting.

I. CHOOSE BASE APPROACH



or

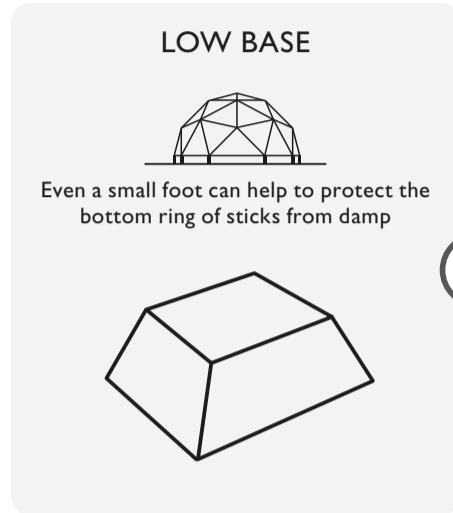

or

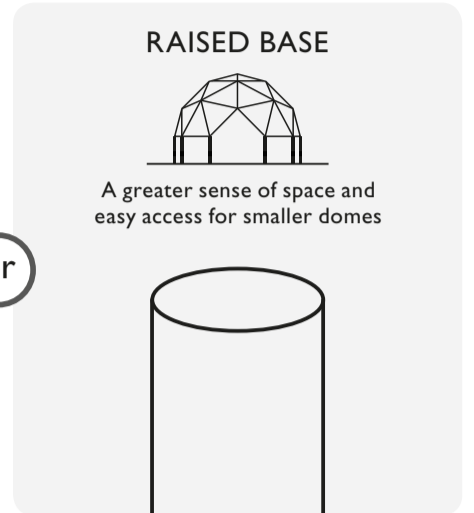

Standing up

Screw two ball connectors 3mm apart onto your base. You could also use two ball connectors in a hub as a template. Test your first attempt in a hub to check that the position is ok.

Tip:
If proving tricky, slightly loosening one ball connector helps.

Lying down

The hub sits horizontally and a screw through the centre of the hub can fix it to the base. It's also possible to use a hub screw if you embed an M6 threaded insert in your base.



Temporary use
It is possible to simply rest your dome on the ground using the lying down approach. Stake through the centre of hubs or stake down the bottom ring of sticks. If the dome is on a hard surface use metal weights or sandbags to secure the base in position.

Small feet

These can simply be blocks of wood. Drill with holes so you can stake them to the ground. You can also add eyelets or hooks for attaching covers.



Not too wide
If the hub is lying down make sure the width of the feet or posts is 70mm (2¾") or less to be sure that they don't clash with the sticks.



Get the angles in the base ring as consistent as you can before fixing in place.

2. CHECK ALIGNMENT

Hubs will want to find the right alignment but after a build some might be out of position.

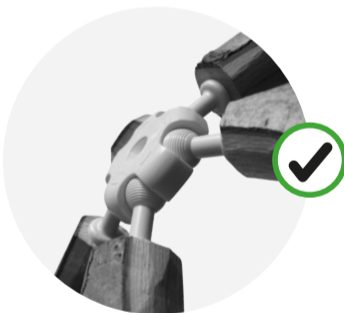

Correct by pulling sticks towards the outside of the dome. Pushing inwards can pop sticks out of the hubs!

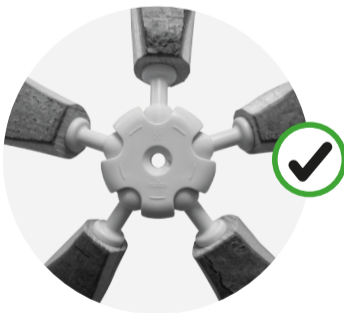
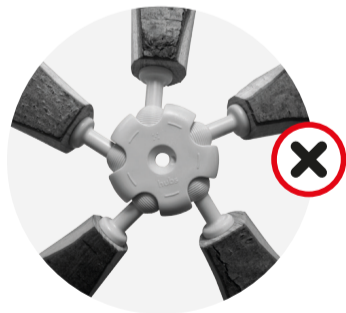

Tap sticks left and right to correct rotational misalignment.

3. CLAMP-UP THE HUBS

Once finger-tight use the allen key to clamp firmly.

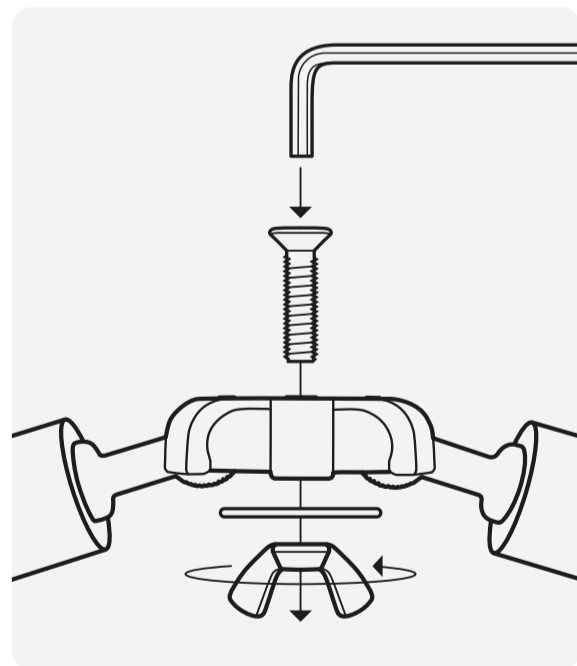

Un-clamp all hubs before moving a dome.
Moving a dome whilst the hubs are clamped-up will damage the hubs and ball connectors!

Taking down your dome



Un-clamp all hubs before taking the dome down.

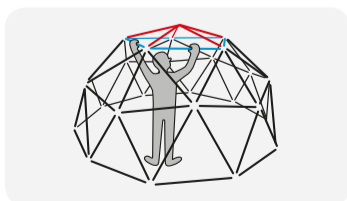

One person supports the weight of the dome by holding the central pentagon as shown (blue).

A second person removes the SHORTS of the central pentagon (red).

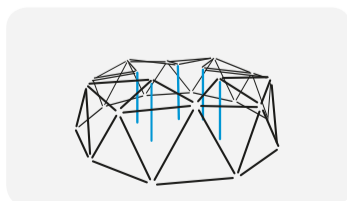

The next sticks to be disconnected can be rested on the ground to support the dome as you dismantle it.

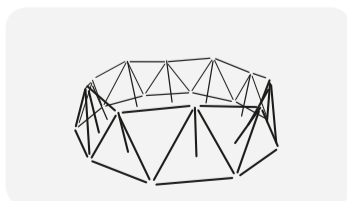

Continue the process until you're back to a collection of hubs and sticks!

